

TR2 LIGHT

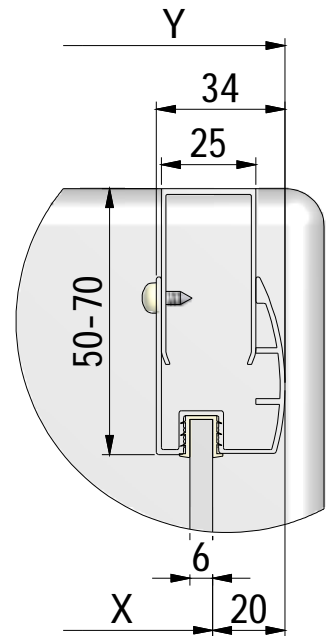

Roltechnik a.s.; Czech Republic, 56933 Třebařov 160,
tel.:+420 461 324 301/302, fax: +420 461 324 297,
<http://www.roltechnik.com>; e-mail: objednavky@roltechnik.cz

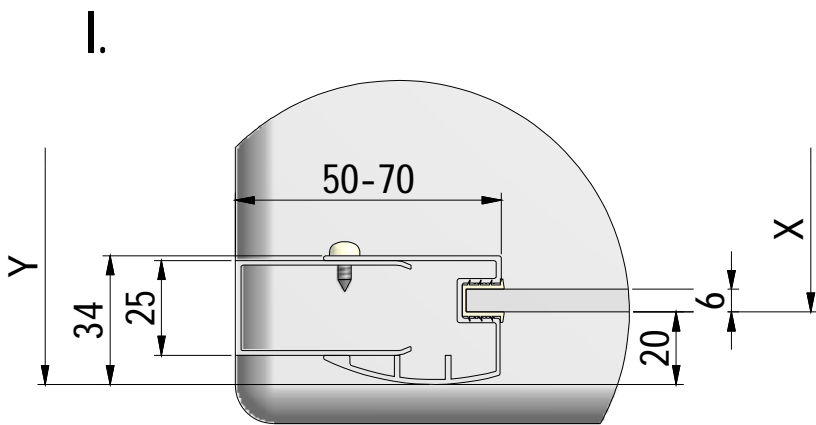
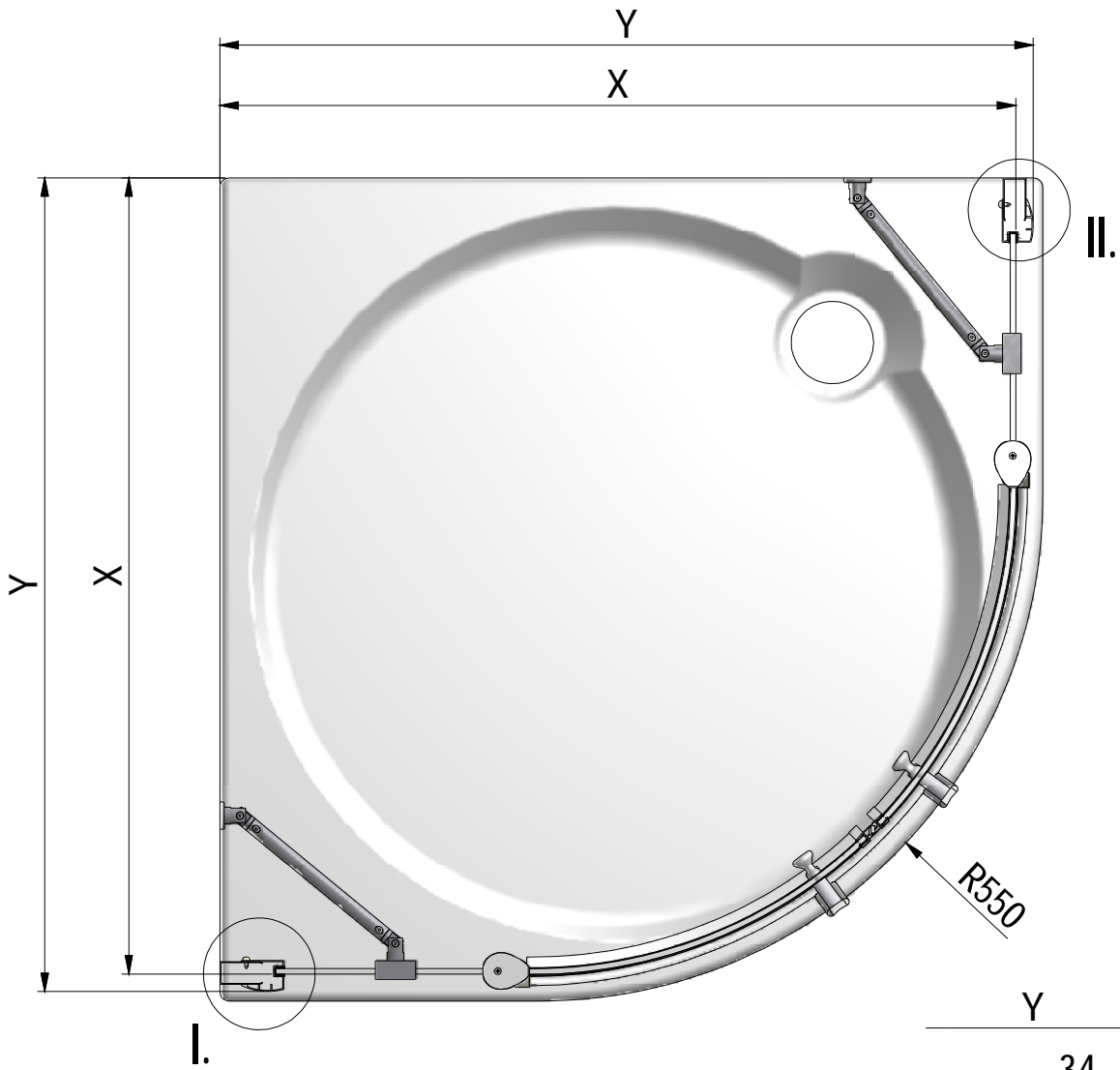

TR2 LIGHT	X (mm)		Y (mm)	
	MIN	MAX	MIN	MAX
900	850	870	870	890

1. 2x
S27



2. 2x
V14

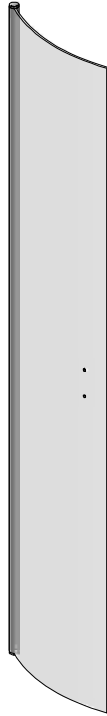

3. 2x
P2873



5. 1x
P2290

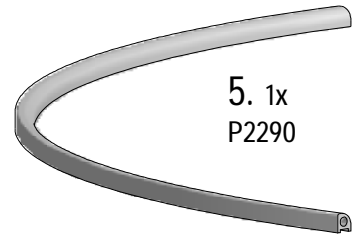

6. 6x
M0511
n6



7. 6x
M0811
3,9x38



12. 2x
M8833

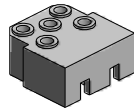

13. 1x
M8835

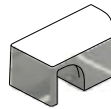

14. 1x
M8834

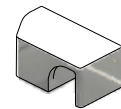

15. 4x
M0797
3,5x45



16. 2x
M0547

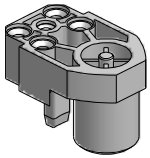

17. 4x
M0793
3,5x25



18. 2x
M1916



19. 2x
M8824

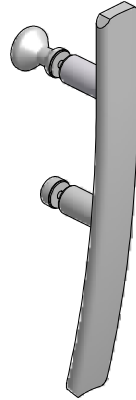

20. 1x
M4174

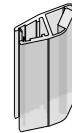

21. 1x
M4175

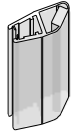

22a. 1x

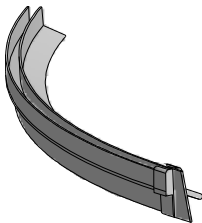

22b. 1x

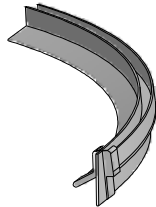

23. 2x
M6473

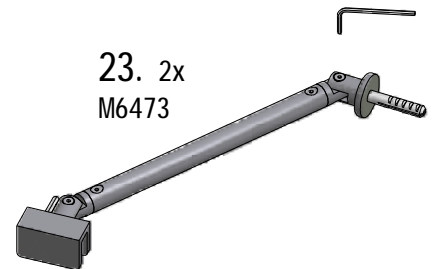

24. 6x
M1907



25. 1x
M0838
n2,8

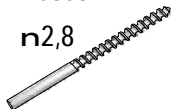

26. 6x
M0806
n3,5x9,5



27. 2x
M1896

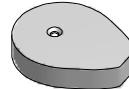

28. 2x
M0800
3,5x45



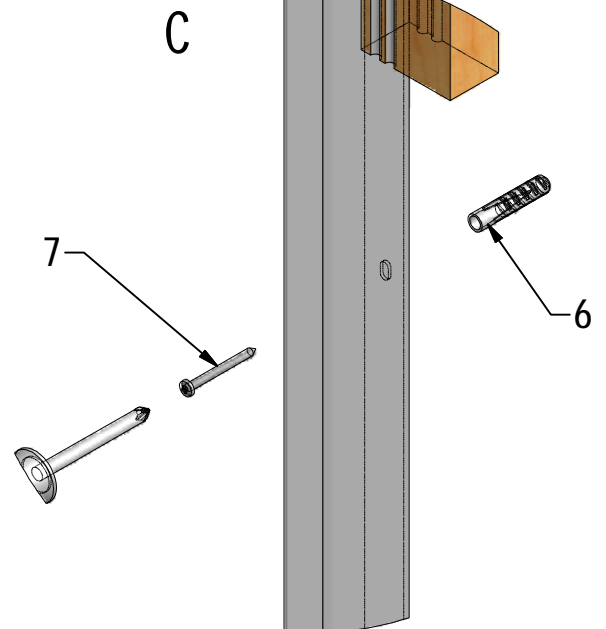
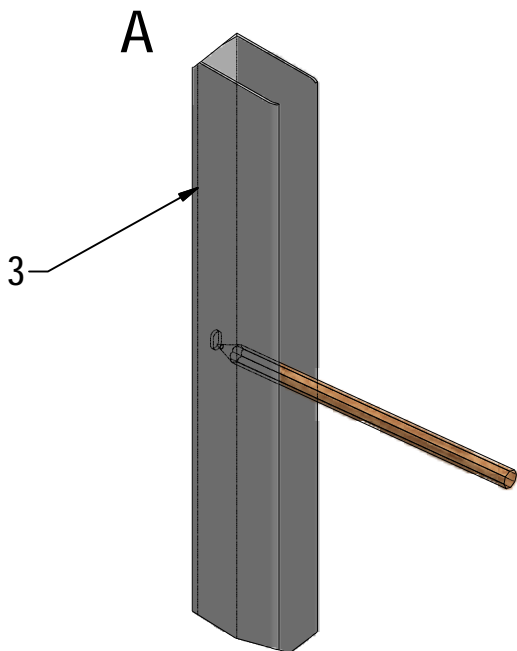
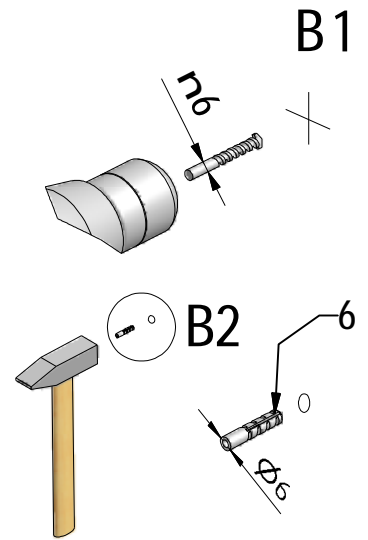
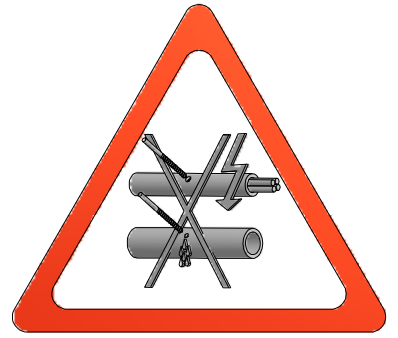
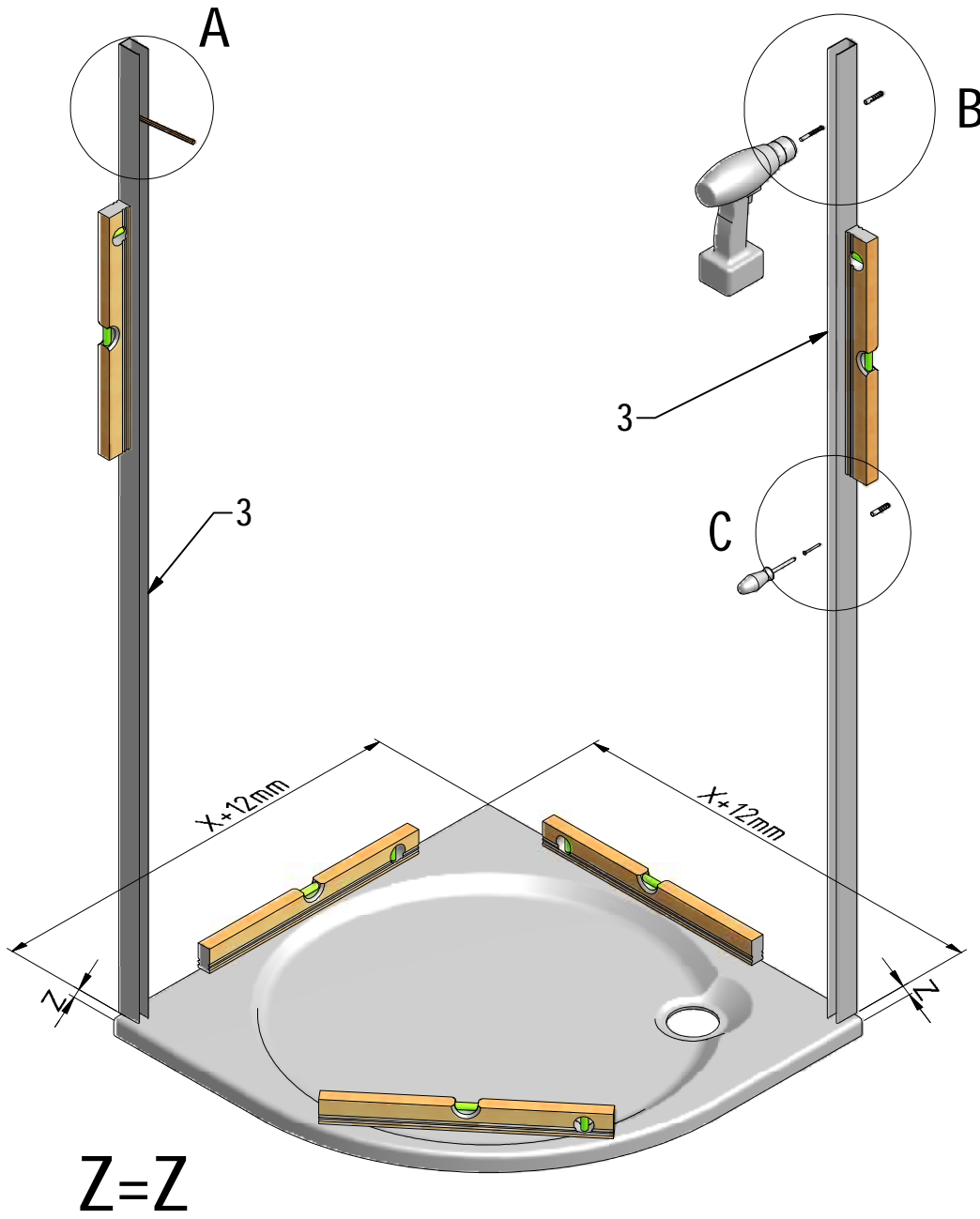

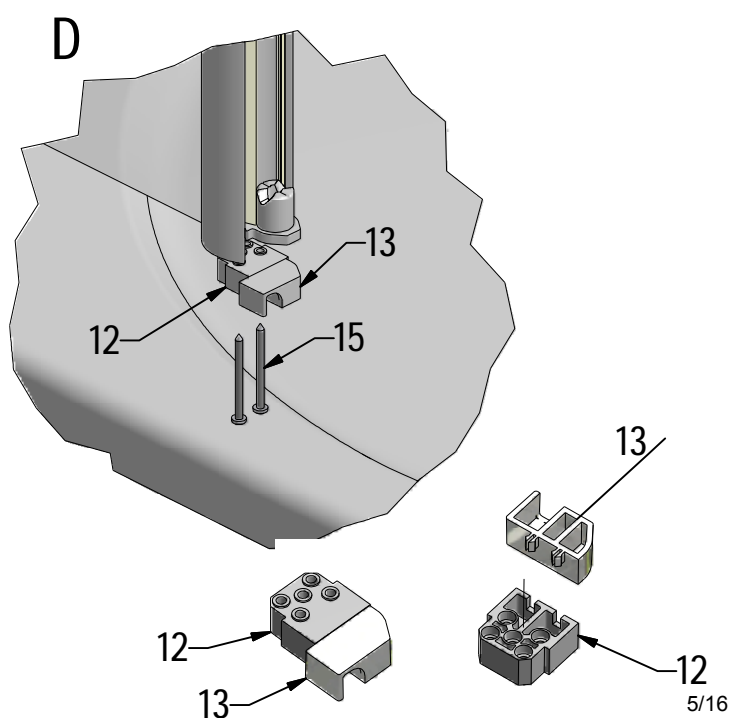
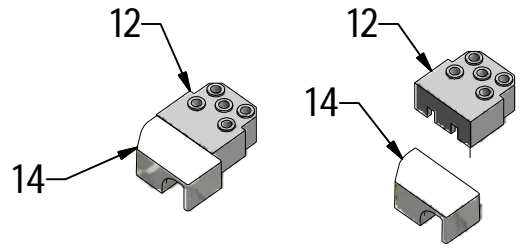
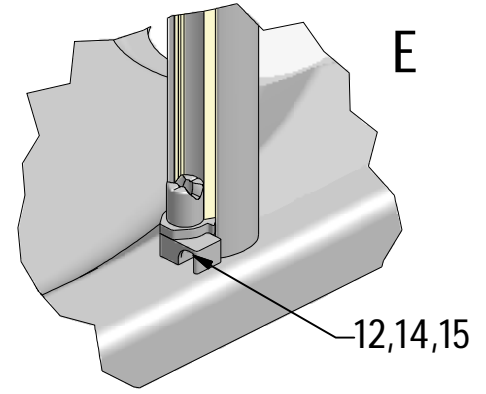
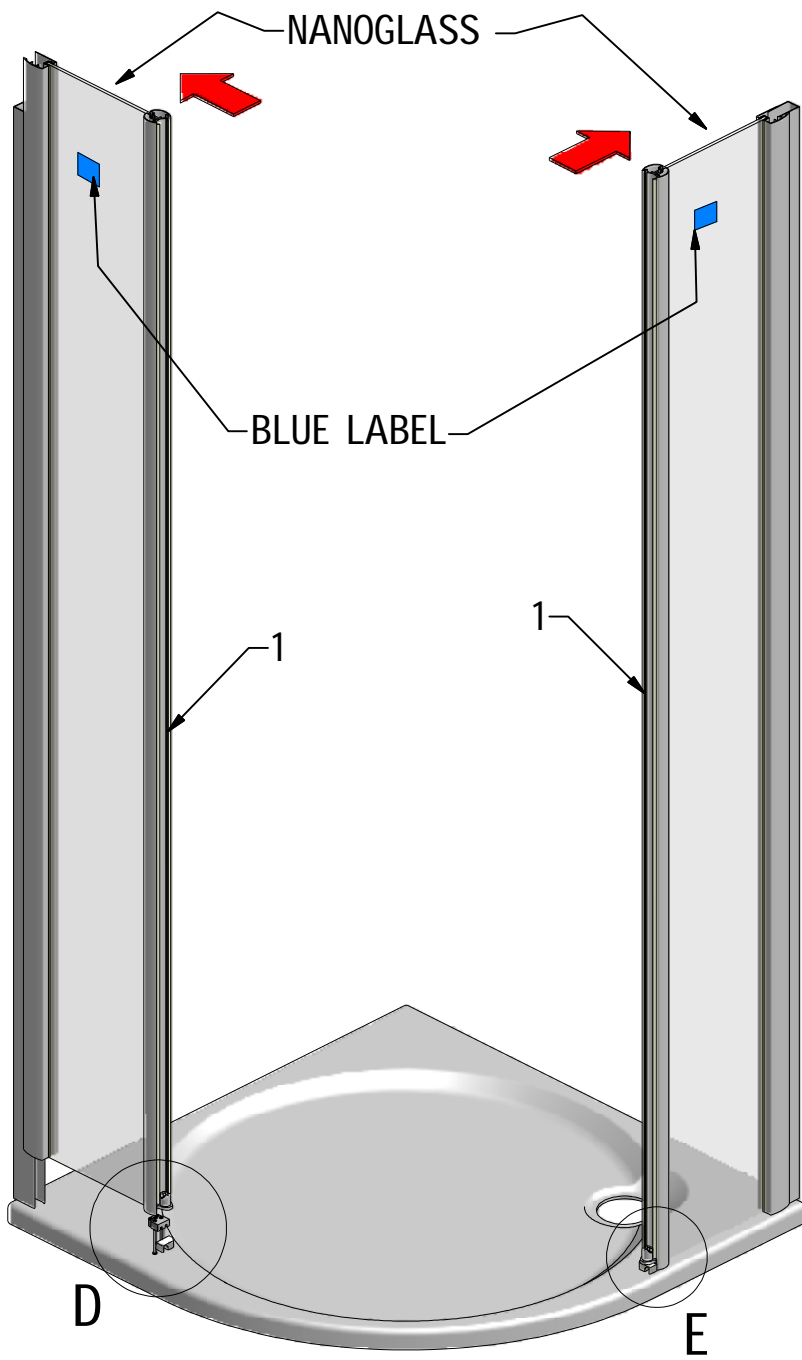

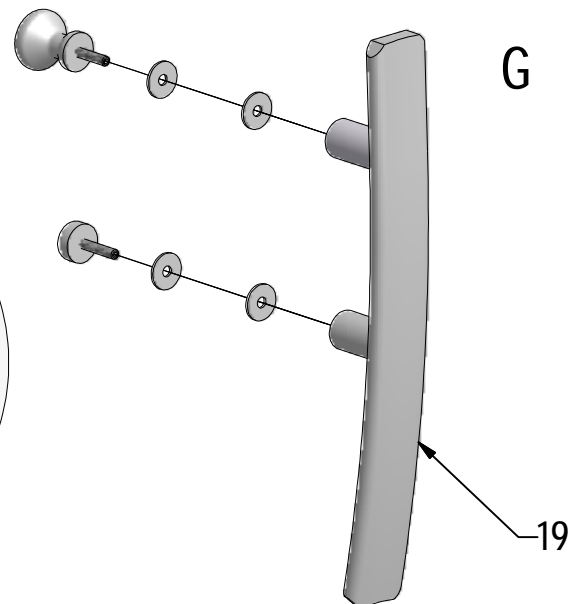
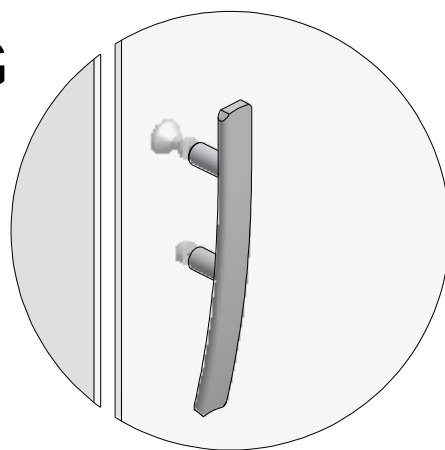
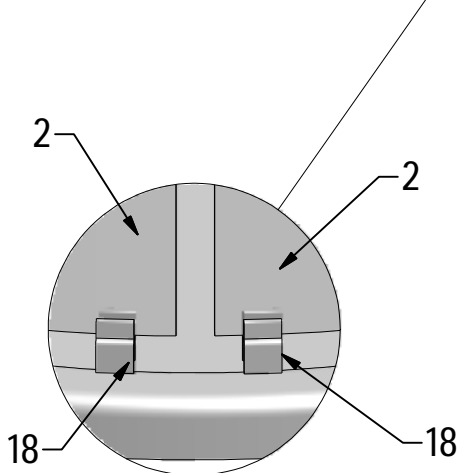
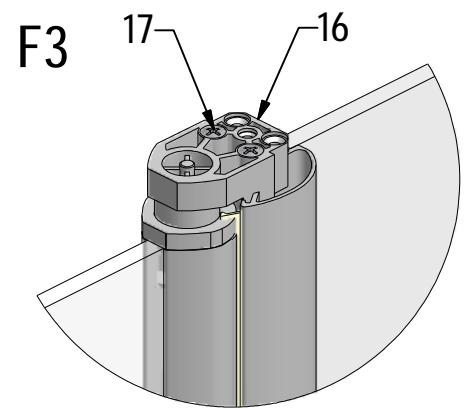
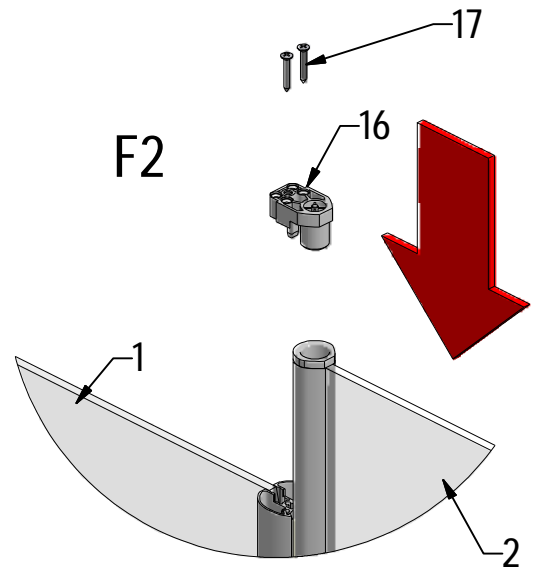
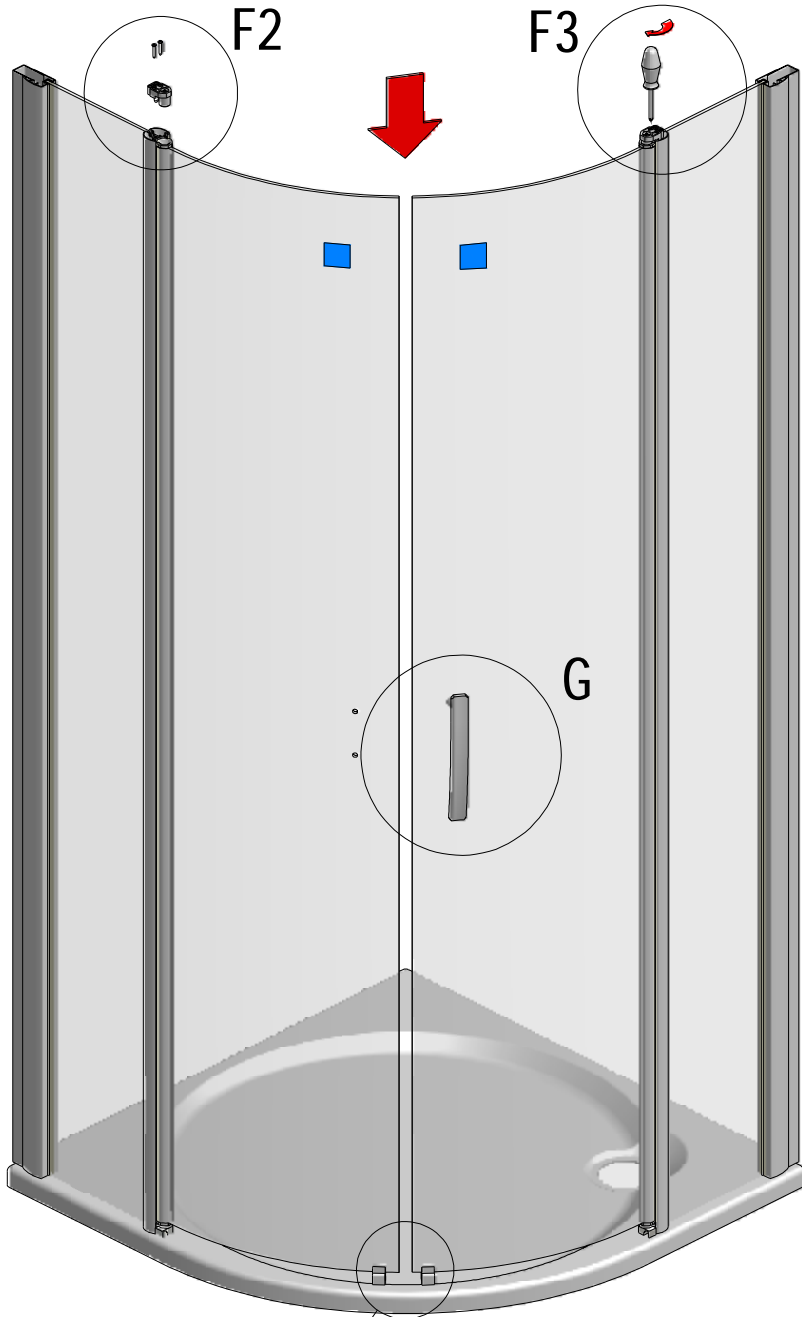
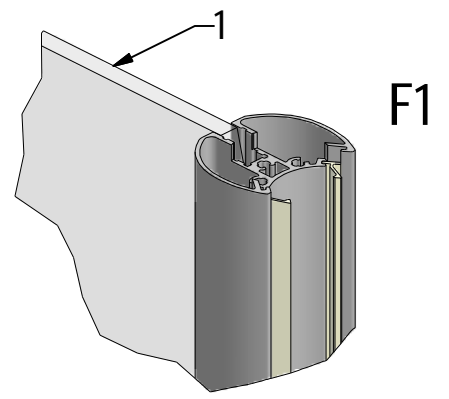
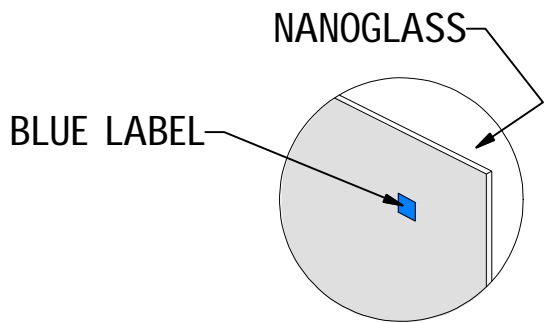

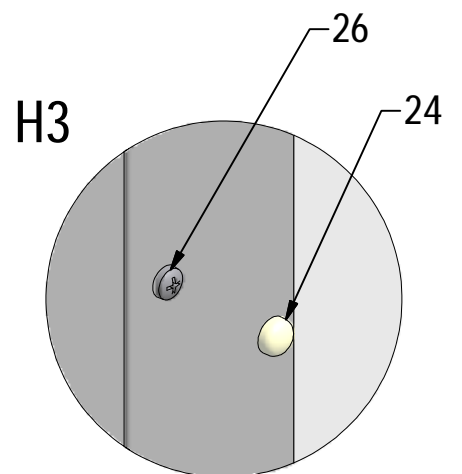
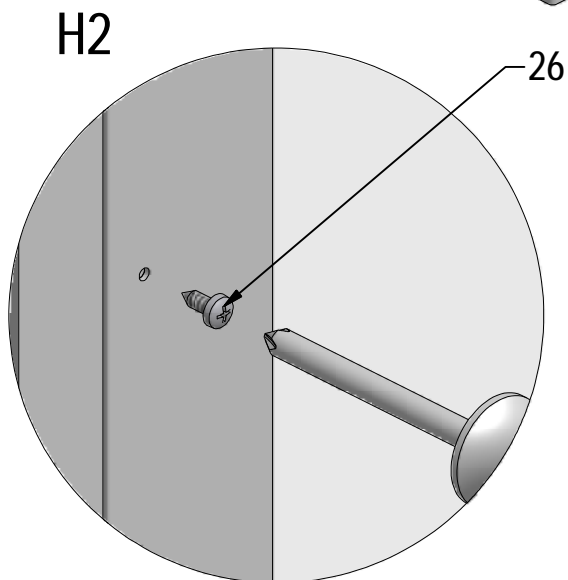
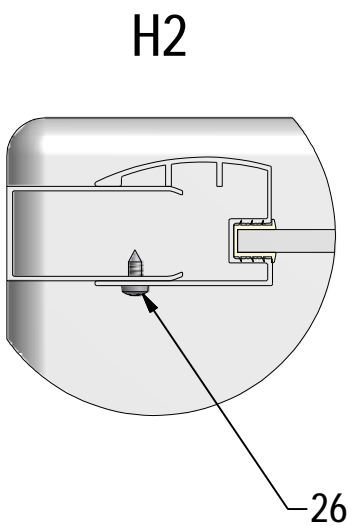
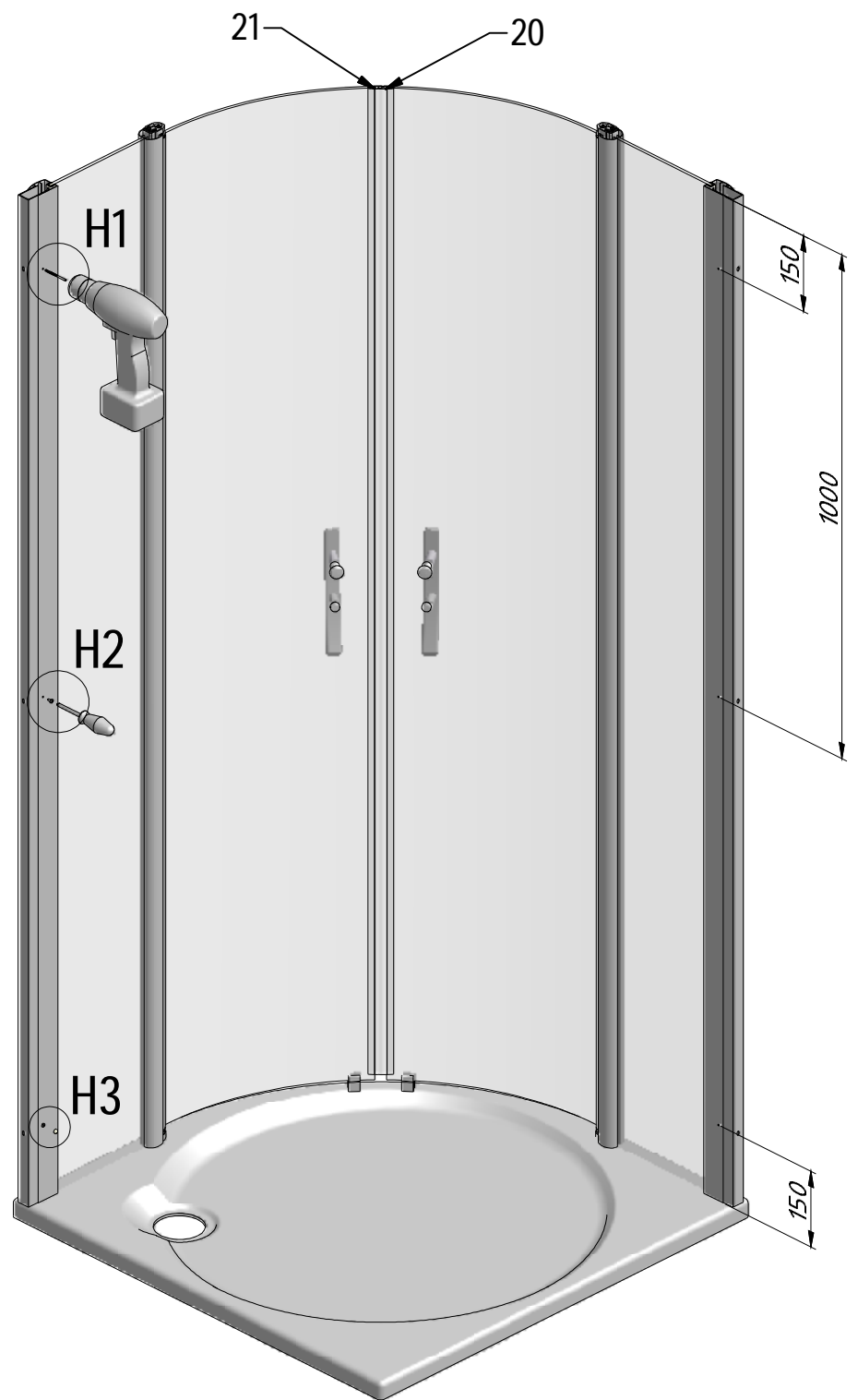
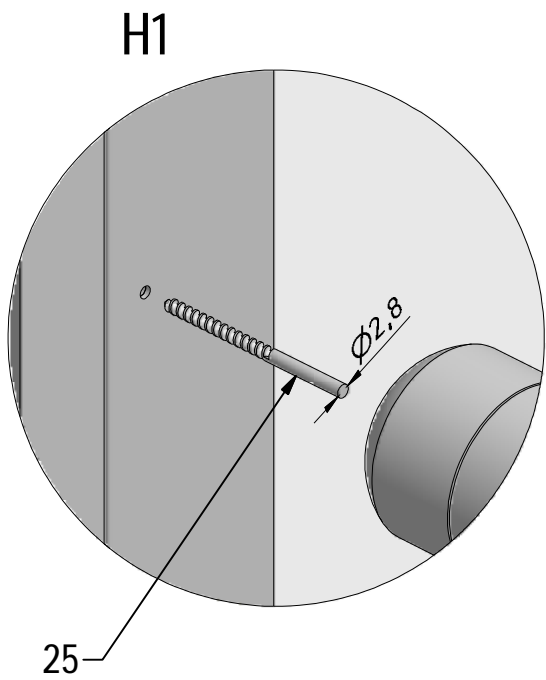
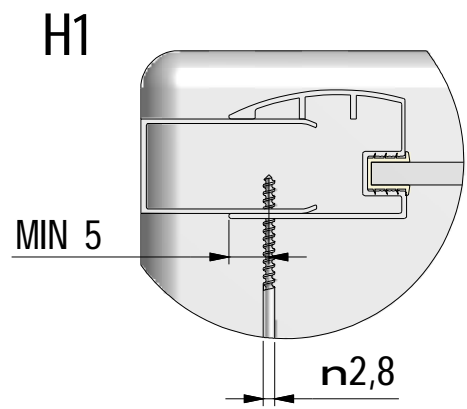

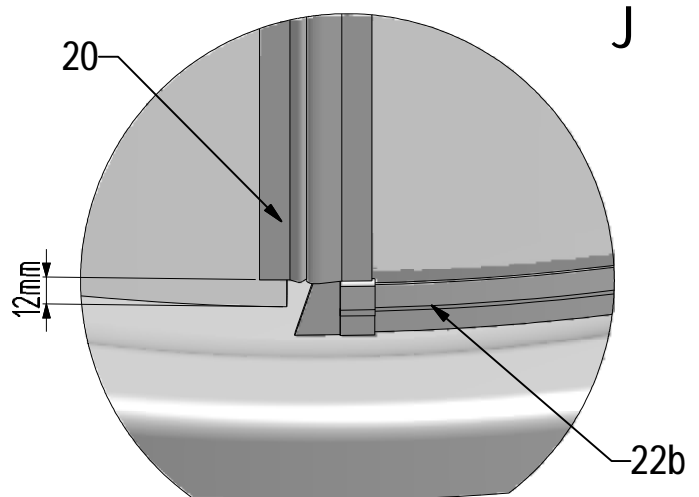
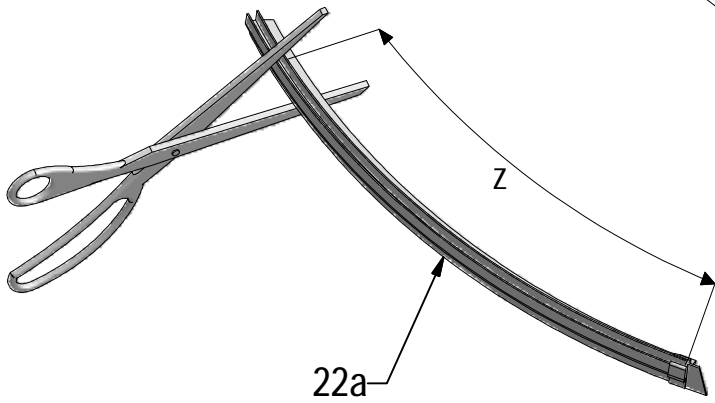
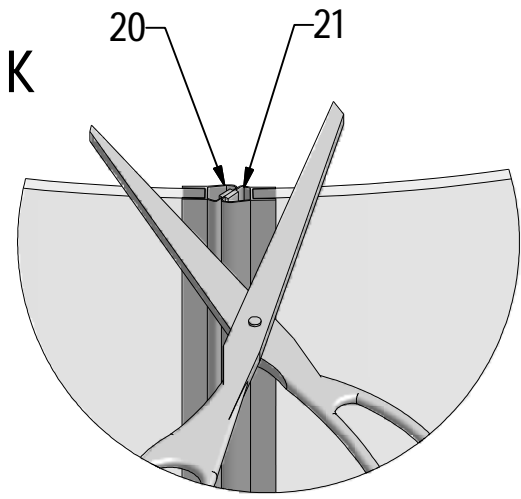



M

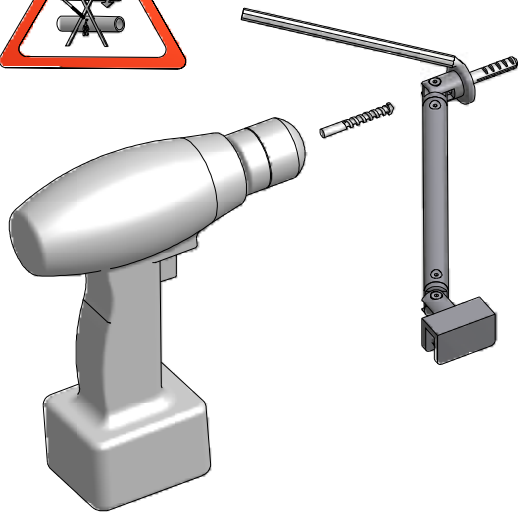

M

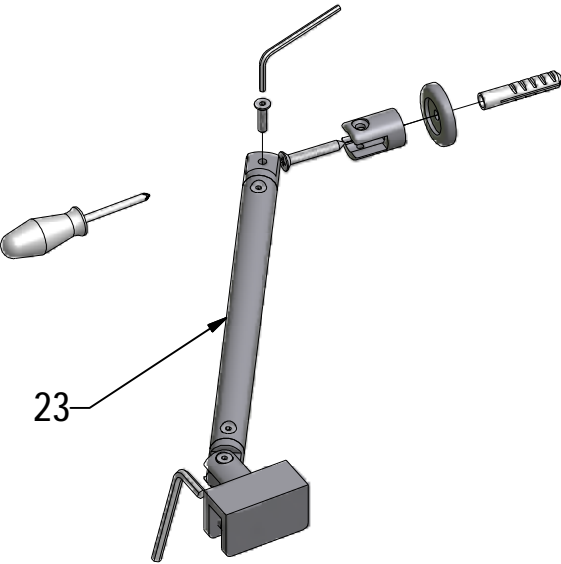

23



L1

L2

L1

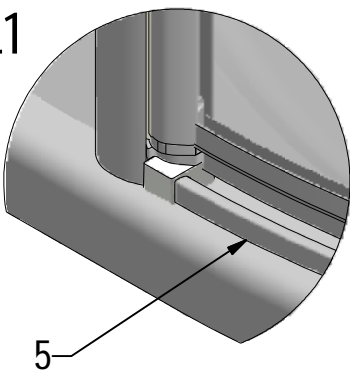

5

L2

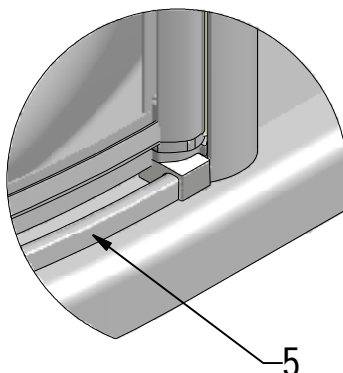

5

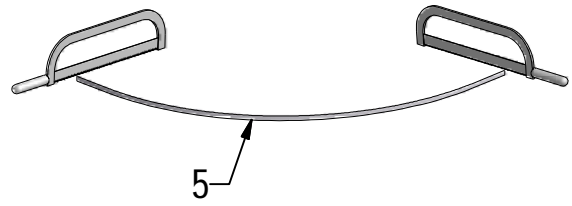

5



N1

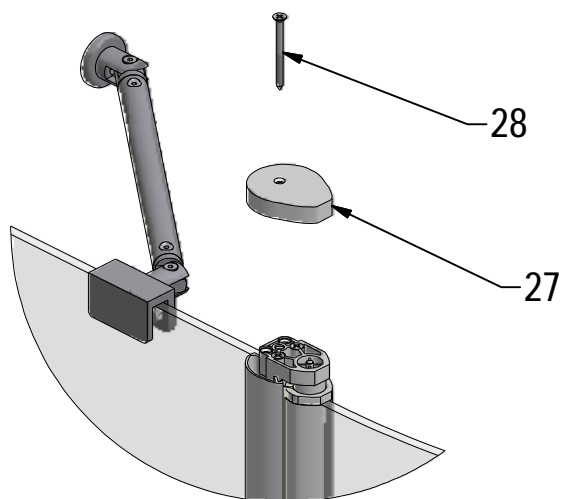

N2

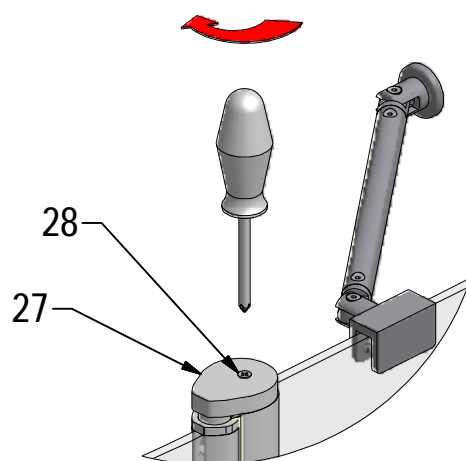

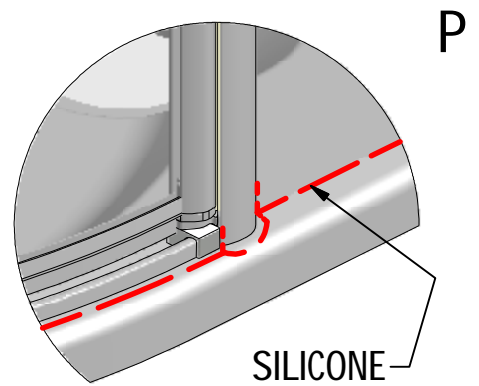
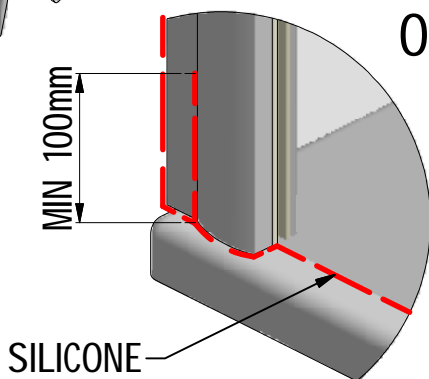
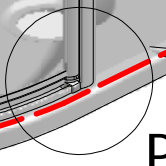
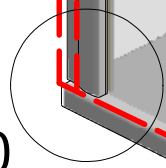
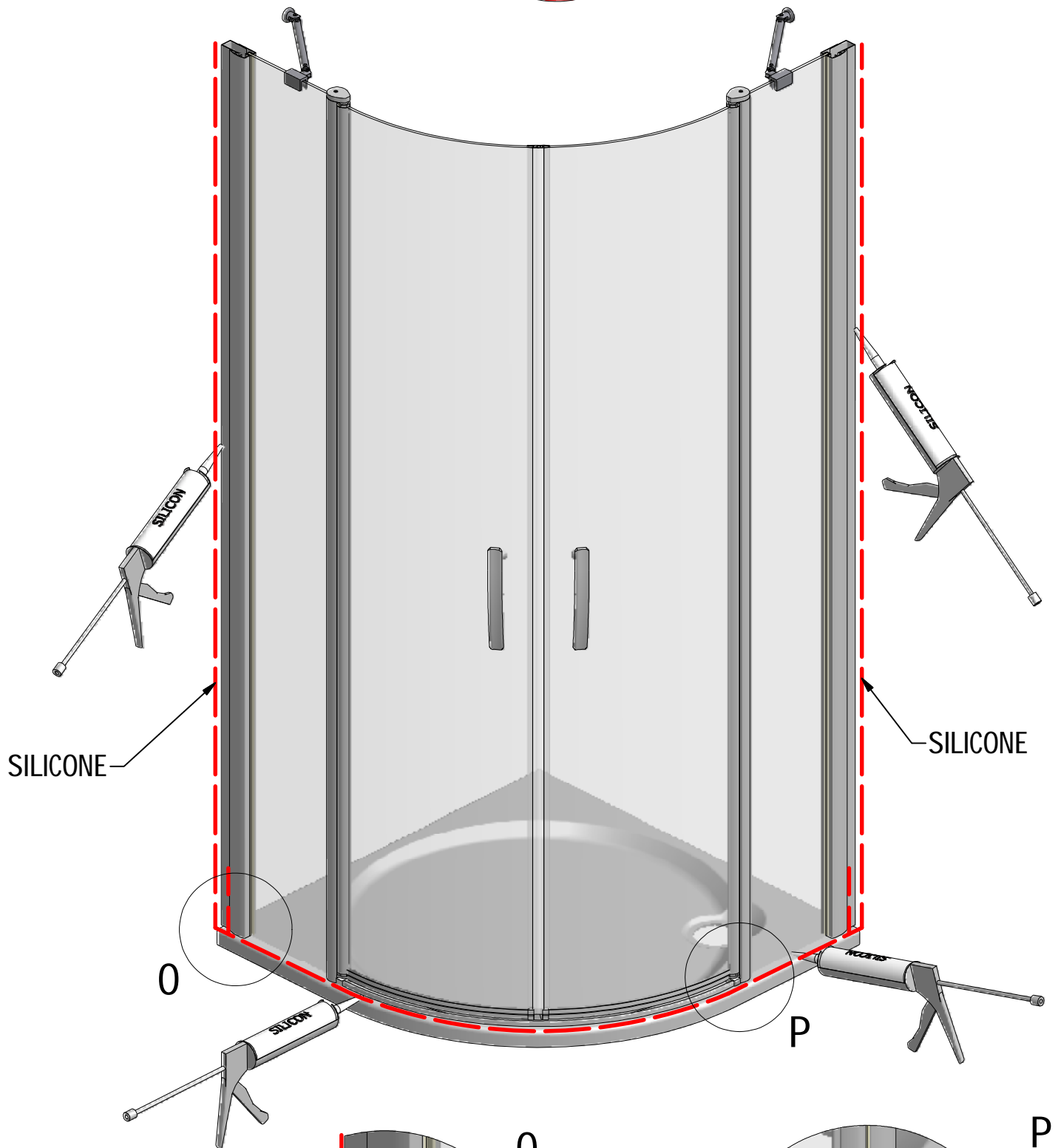

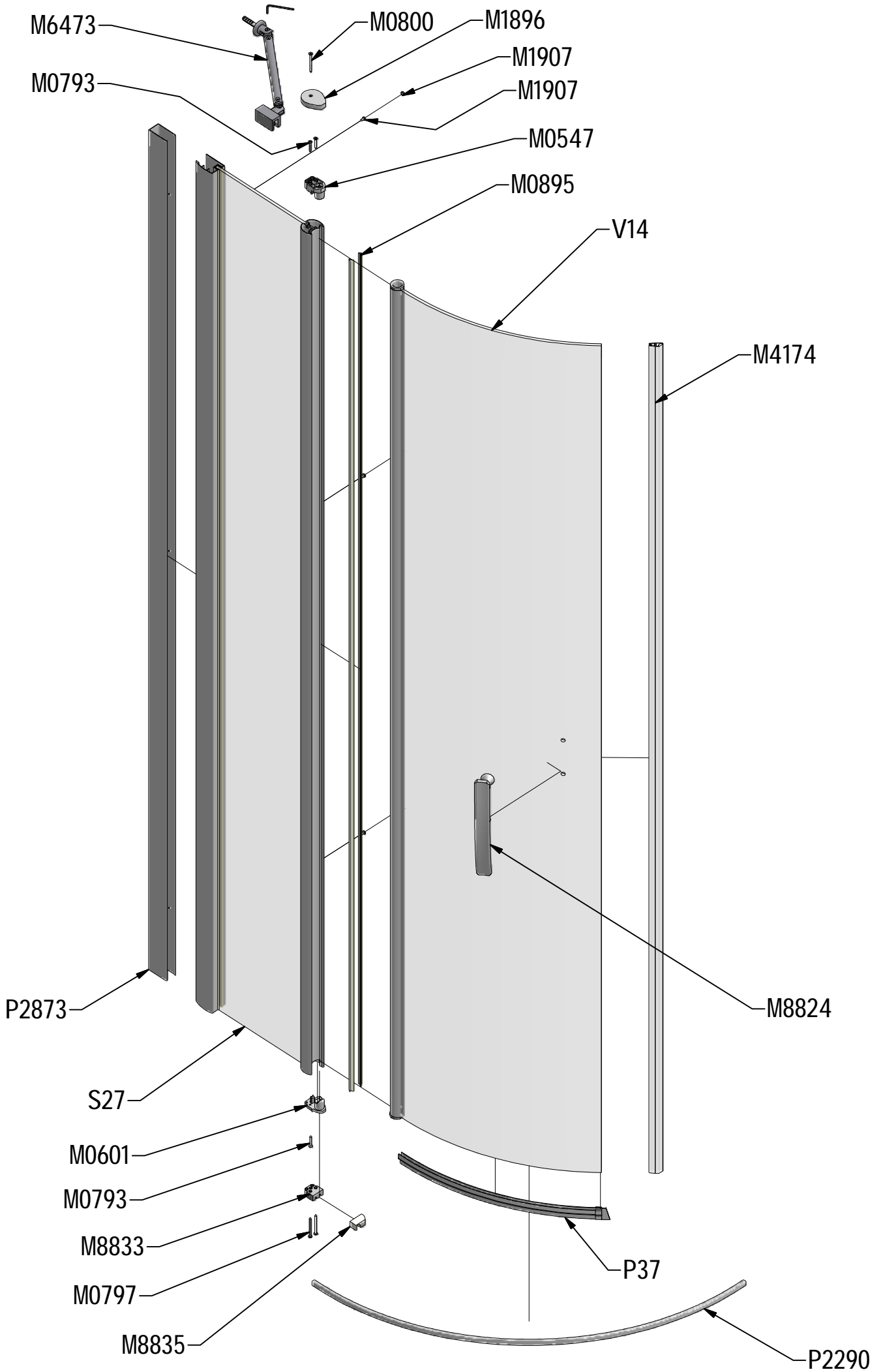

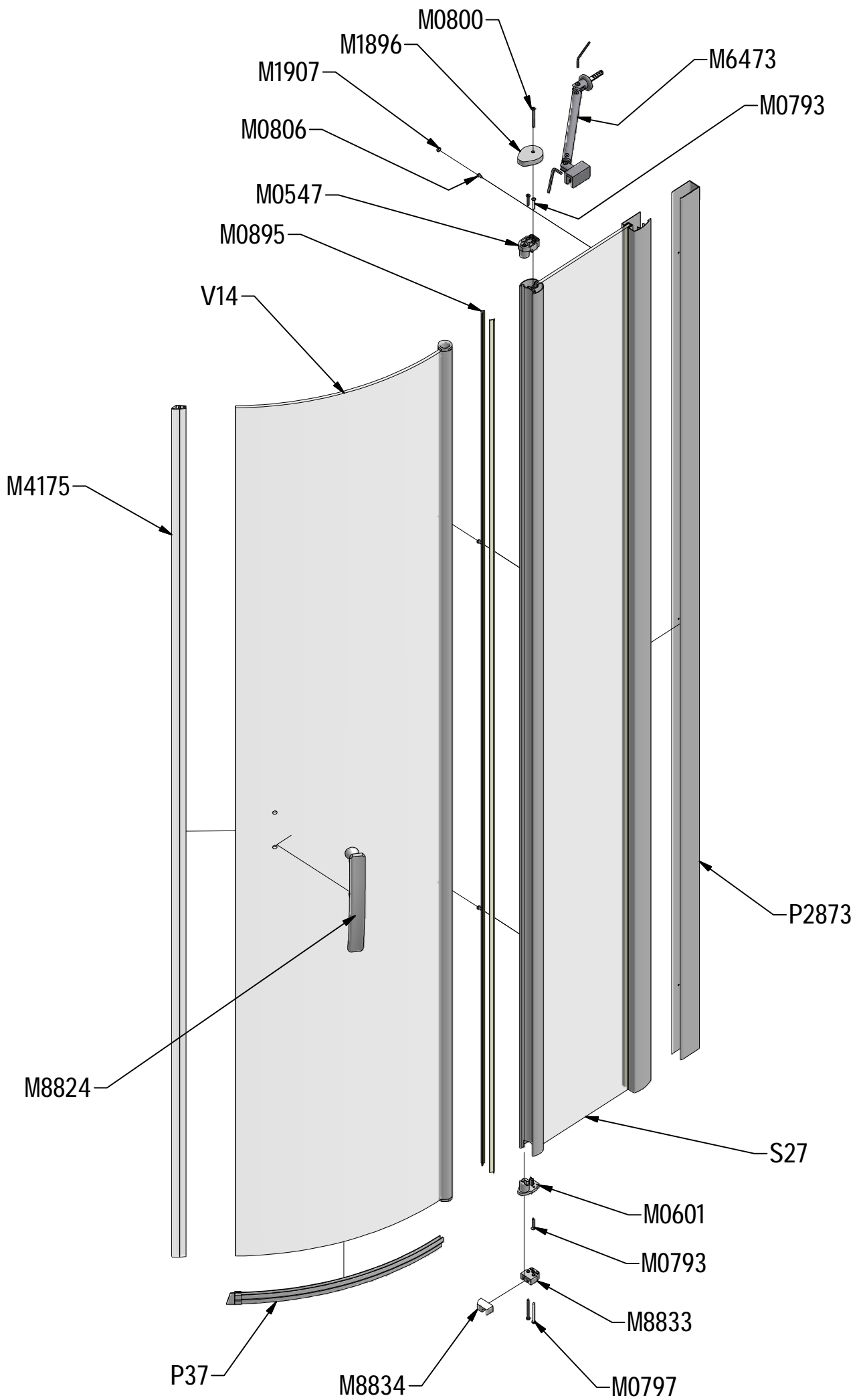

S27

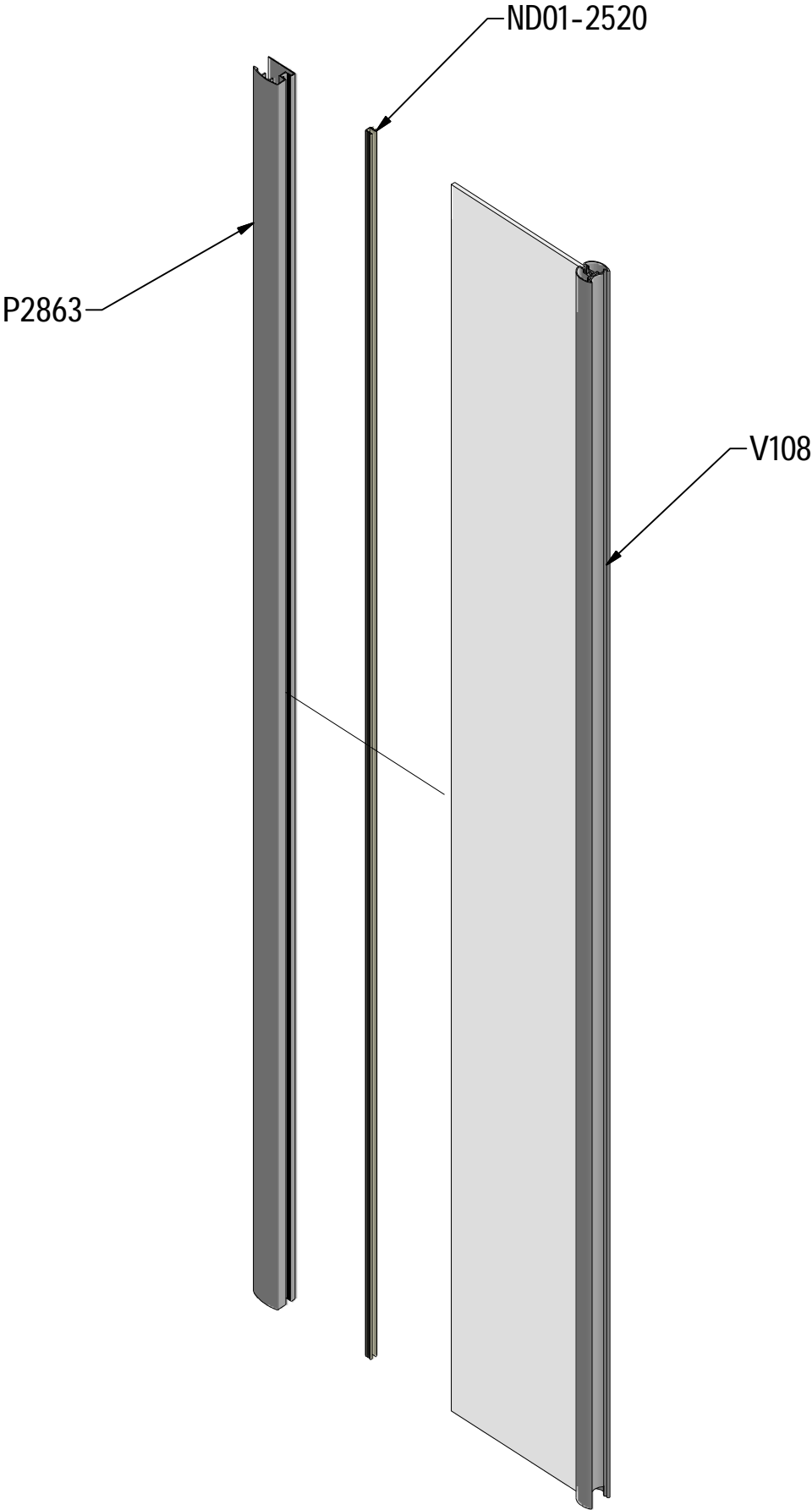

P37	900			ND01-2421
S27	900	brillant+clear glass		ND02-0632-00-02
V14	900	brillant+clear glass		ND02-0508-00-02
V108	900	brillant+clear glass		ND03-0478-00-02



**ROLTECHNIK a.s. / Třebořov 160 / 569 33,
CZECH REPUBLIC**

11

EN 14428:2008+A1